



SKY FLIGHT HOBBY CO.,LTD

YF-23



Instruction Manual



WARNING

A R/C model airplane is not a toy and is not suitable for flyer under 14 years old. Read the instructions carefully before any use. If you are a beginner, it is necessary to let an experienced airplane pilot assist you.

Meaning of the icons.

-  ● **WARNING!** : this symbol indicates where caution is essential to avoid injury to yourself or others .
-  ● **PROHIBITED:** this symbol points out actions that you should not do to avoid possible damage or accidents.

Safety instructions

1. Do not fly in thunderstorm, strong winds or bad weather.



2. Never fly the Model where are crowds of power lines overhead , automobiles or near highways , subways.

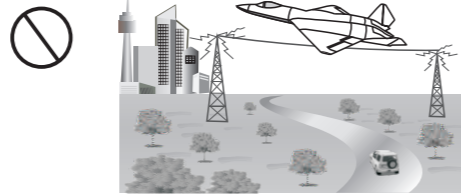

3. Never fly the Model where are crowds of people. Give yourself plenty of room flying , as the plane can travel at a high rate of speed . Remember you are responsible for the safety of others.

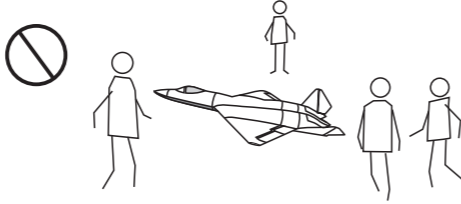

4. Do not fly in where the same frequency model plane is flying nearby.

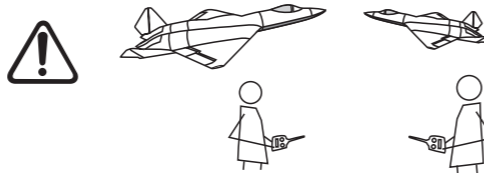

5. Make sure that the model as well as the control system is in the good state before the plane takes off.

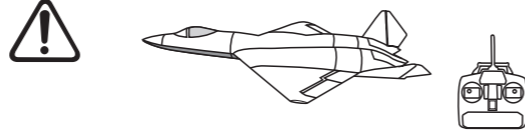

6. Only use genuine accessories as replacements for damaged parts.



7. Do not attempt to catch the model while flying.

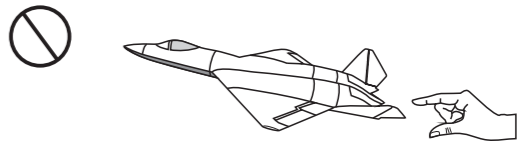

8. Not recommended for children under 14 years old, Children under 14 years old should only operate this model under the guidance of a responsible adult.

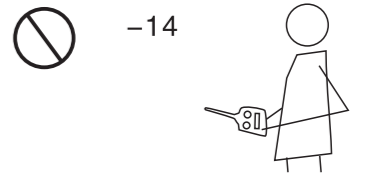

9. Do not store this model in a high-temperature or humidity area or in direct sunlight.

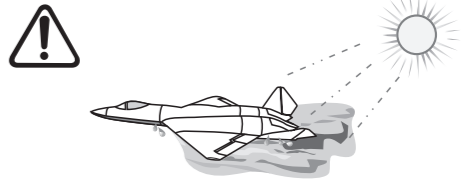

Thank you for purchasing YF-23.

YF-23 is a jet plane with twin 70 EDF which suits for intermediate or senior aviators .

In order to fly the YF-23, please make sure you read through the instructions carefully before attempting to operate the model for the first time.

If you have any questions in regarding to the safe operation, or possible precautions please call your local hobby shop for professional advice.

Radio-controlled models are very demanding and potentially dangerous machines. They call for a high level of technical knowledge and skill from the operator. Please always keep this instruction manual ready at hand for quick reference, even after completing the assembly.

Note: SHENZHEN LANXIANG MODEL AIRCRAFT CO.,LTD will not take any responsibility for damage or accident caused by the improper use of this model.

Instruction for transmitter

- A** Retract control switch
- B** Flap control switch
- C** Vector SW switch
- D** Dual rates servo SW switch
- E** Throttle, rudder rocker
- F** Elevator aileron rocker
- G** Mode 1/2 SW switch
- H** Mixed control switch



SW-A (Function switching over 1, 2 mode)
 SW-B (CH7,CH8,CH9 channel switching over);
 SW-C (CH1,CH2 channel mixed control / unmixed control switching over SW)
 SW-A ON,SW-B ON, SW-C MIXED, turn on radio system:CH1 and CH2 mixed control, CH7 and CH2 synchronization,CH9 and CH1 synchronization, CH8 and CH4 synchronization; when the radio system power is turning on, SW-A switching over invalid, when SW-B OFF, CH7,8,9 on center. SW-A ON, SW-B OFF, SW-C MIXED,turn on radio system:CH7, CH8,CH9 autonomous working,CH1 and CH2 mixed control ; when the radio system power is turning on: SW-A switching over invalid,SW-B switching over invalid.
 SW-A ON, SW-B ON, SW-C MIXED, turn on the radio system:CH1 and CH2 mixed,CH7 and CH2 synchronize (CH7 and CH1 unmixed control), CH8 and CH4 synchronization ; when the radio system power is turning on:SW-A switching over invalid, SW-B switching over invalid.
 SW-A OFF, SW-B OFF, SW-C MIXED,turn on the radio system: CH1 and CH2 mixed,CH7, CH8, CH9 autonomous working; when the radio system is turning on:SW-A switching over invalid,SW-B switchingover invalid.

Pictures for receiver connection



- CH12: Color smoke
- CH11: Pilot ejection
- CH10: Parachute
- CH9: Vector 3(Up and Down)
- CH8: Vector 1(Left and Right)
- CH7: Vector2(Up and Down)
- CH6: Flap
- CH5: Retracts
- CH4: Rudder
- CH3: Throttle
- CH2: Elevator
- CH1: Aileron

Frequency method for remote control

1. Open the back cover of the remote control, mounted on the 8 pieces AA batteries.
2. Press the button on the receiver, then plug the power of receiver (to the receiver supply voltage is 5V), after plugging in the power and release the button, then the receiver's LED flashes, then open the remote control switch, when the remote control is turned on the LED will light up after flashing quickly about 2 seconds. the LED on the receiver lights up means frequency matches up successfully.
3. If the LED on the receiver is still flashing then repeat the steps above.
4. The steps of using the remote control properly: first, the throttle stick to the lowest, and then turn on the remote control, and then the middle LED on the remote control will flash, then connect to the receiver power till the LED lights up.
5. Remote control of the factory has been fixed the frequency, and do not need to do it again. if you encounter the LED on the receiver is flashing, check whether the remote control is turned on or not (you can check the middle LED on the remote control is lighted up or not). if not turning on the remote control, LED on the receiver will flash as well. and if the remote control has been turned on and still not working then try to fix the frequency again.
6. There are 3 LED on the remote control is used to identify the remote voltage is normal or not. the green one in the middle lights up long time means the voltage is normal; the green one in the middle lights up long time and red ones on both sides flash means the voltage is too low and please replace the battery or charge the battery.

4 Cells Li-Ion/Li-Poly Balance Charger (Voltage Display Combo)

Specifications

Operating Voltage Range: 9V-16V DC
 Operating Temperature: -20 -45°C
 Cells Type Supported: 2-4 cells Li-Ion/Li-Poly
 Input Power Request: recommend $\geq 30W$
 Max Charge Power: 25W
 Charge Current: 1500mA

Charge Accuracy: $\pm 10mV$
 Balance Current: 1000mA
 Display Accuracy: $\pm 10mV$
 Weight: 76g
 Dimensions: 81*50*20mm (L*W*H)

Device Views

INPUT: DC 9-16V

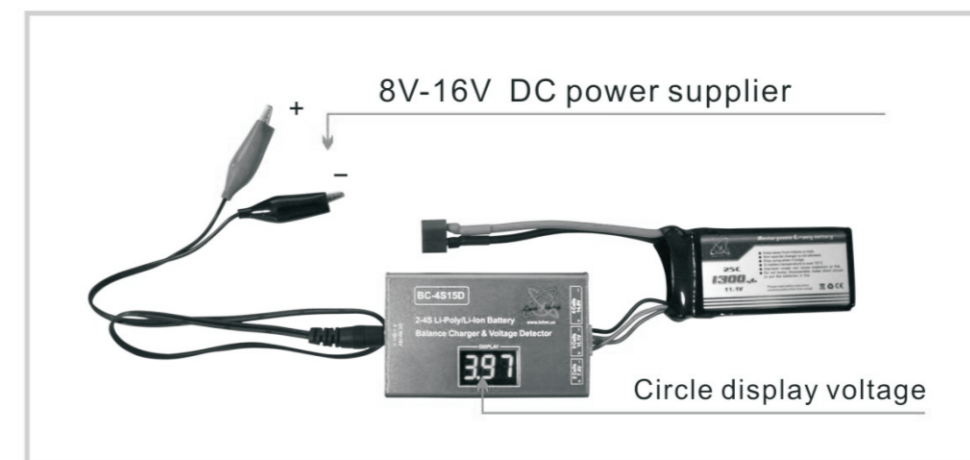
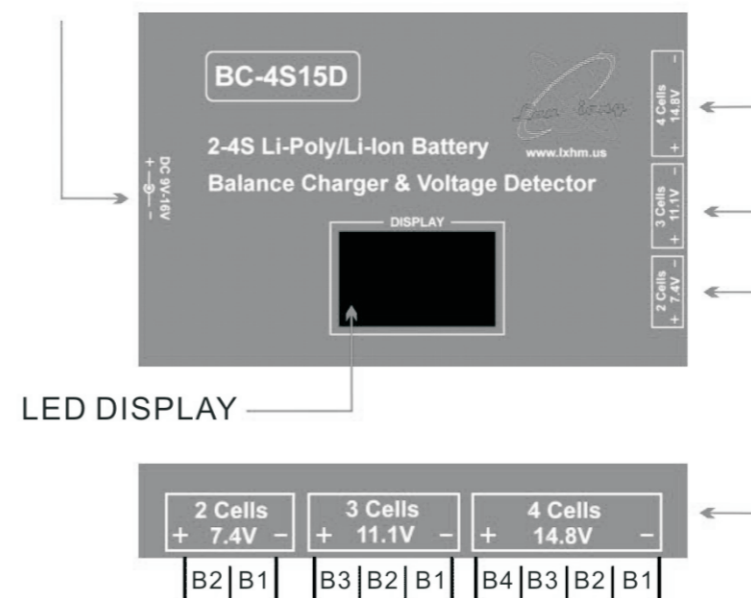

WARNING

- ⚠ Make sure your adaptor has enough power for charging ($\geq 30W$ is recommend)
- ⚠ The range of input voltage is 9V-16V DC
- ⚠ This charger is designed for Li-ion/Li-poly battery only
- ⚠ Do not connect more than two balance lead socket at any time.

Start and stop charging

After power on, the charger will emit a beep and display; `---`
 Plug-in the battery, the charger will beep twice to launch charging.
 The voltage of each cell will be displayed on the LED screen by turns;

`ALL` → `12.6` → `b-1` → `4.20` → `b-4` → `4.20`

The charger will automatically stop when the battery is full, `FUL`
 Will flash with the beep every 5 seconds to indicate the status.

Voltage display

Connect the balance lead socket only, the voltage of each cell will display on the screen by turns.

`ALL` → `12.6` → `b-1` → `4.20` → `b-4` → `4.20`

Error Codes

If charger detected error, charging will stop. Display shows error code, and the buzzer alarms. Reconnect adaptor to restore the charger.

- `Er0` - `Er8` Self-safety-check can not pass
- `Er2` The input voltage or power is out of range
- `Er9` One or more cells of the battery is bad

SPECIFICATION:

Length:1300mm
 Wingspan:809mm
 EDF diametre:2×70mm
 Flying weight:2600g
 Thrust: $\geq 2600g$

CONTENTS INCLUDE:

12CH RC
 2×50A brushless ESC
 1×5A UBEC
 7×digital metal servo
 3pcs screw servos
 2×2100KV Out brushless motor
 6S 25C 4000mAh battery
 electric brake



1 General view schedule.

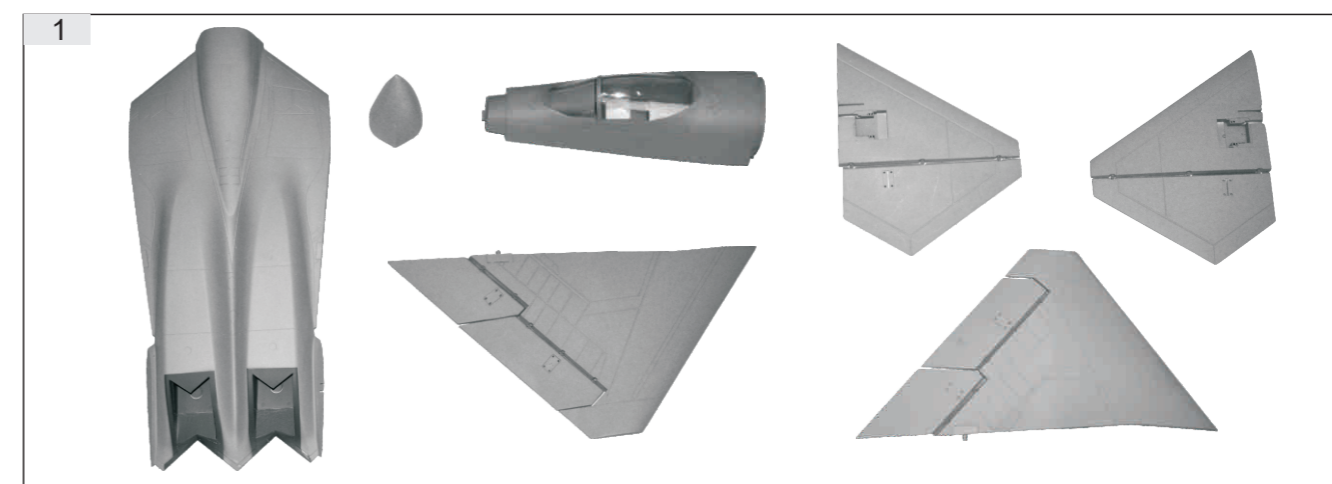

2 Front fuselage installation

(1) The installation for front retract steering, the extension cord of retract servo.(2~3).

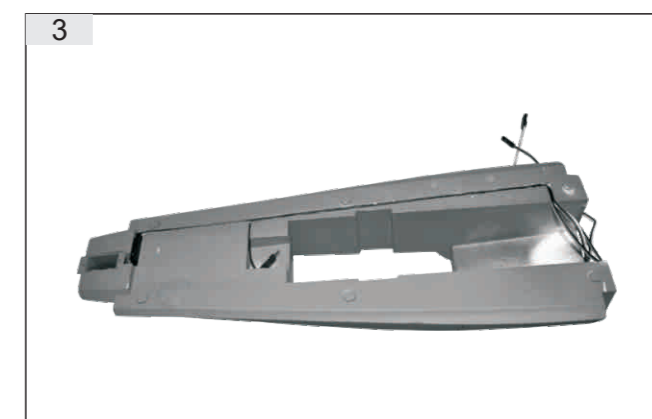
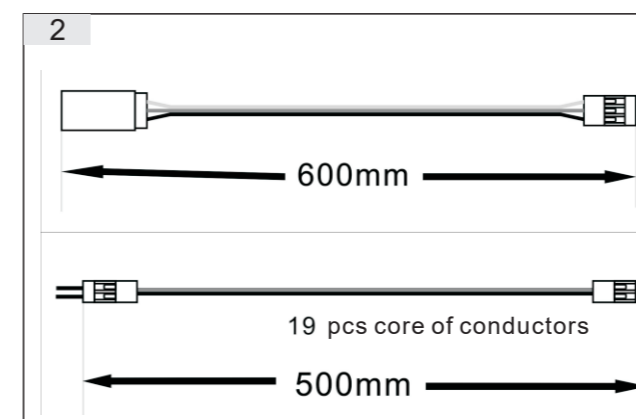

(2) The installation of steering servo in front retract (4~5).

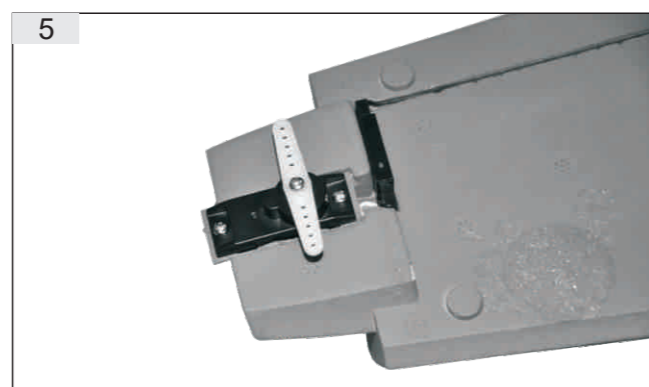
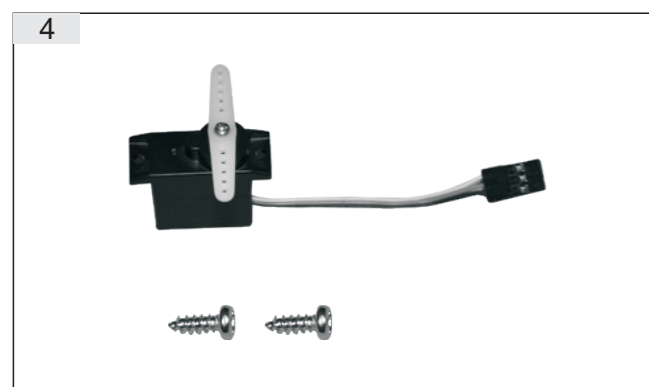

(3) The bonding of front fuselage (6~7).

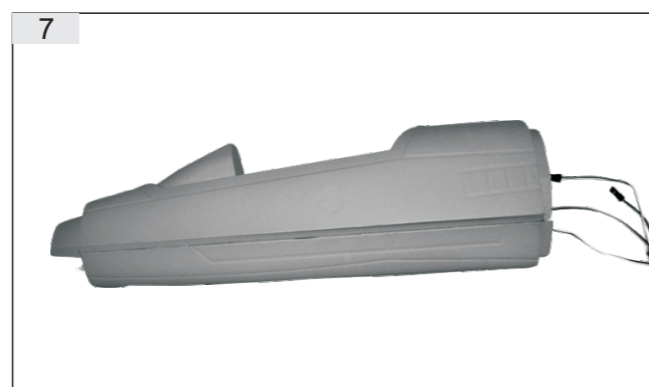
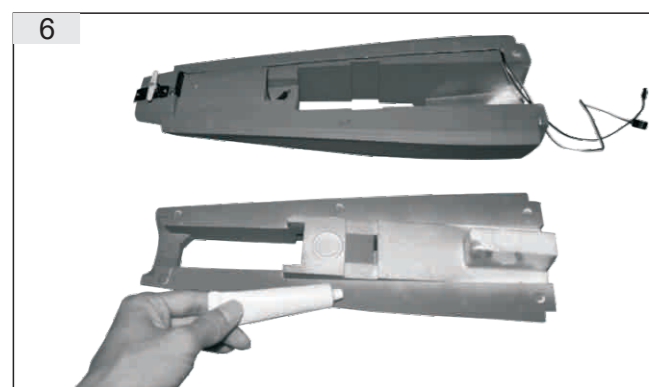

(4) The installation of front retract (8~9).

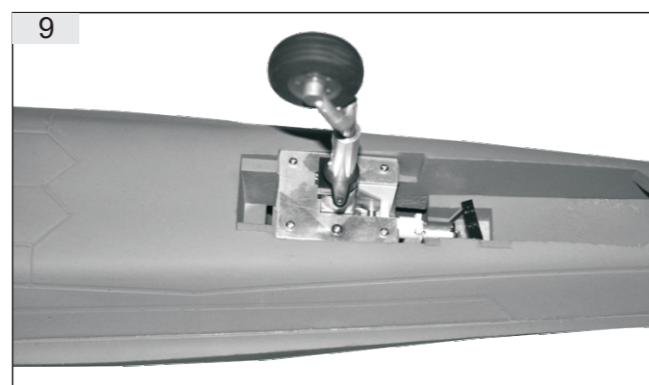
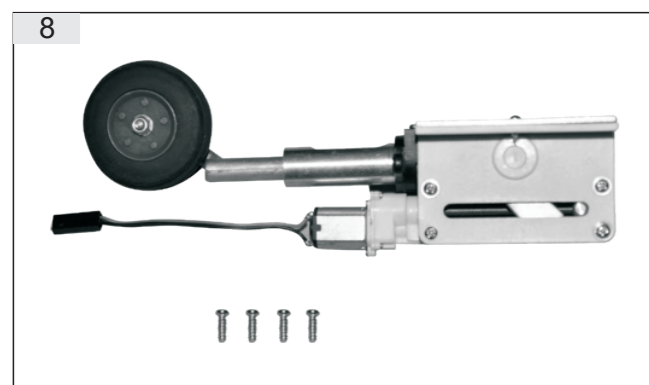

(5) The installation of front-wheel steering (10~16).

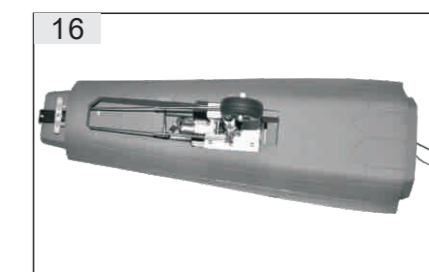
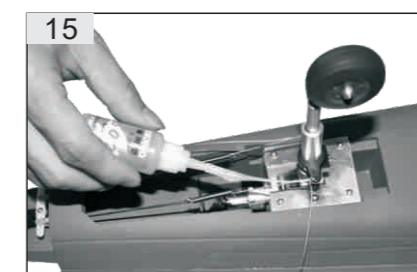
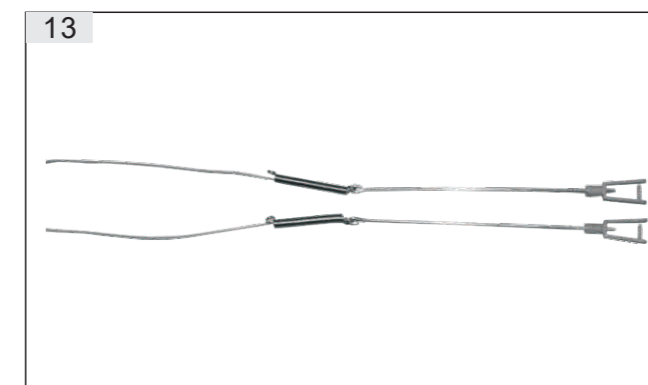
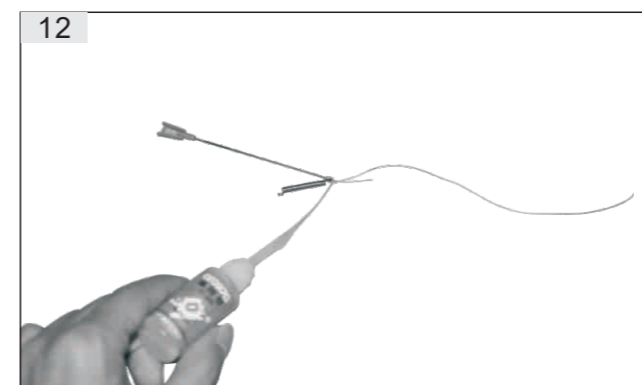
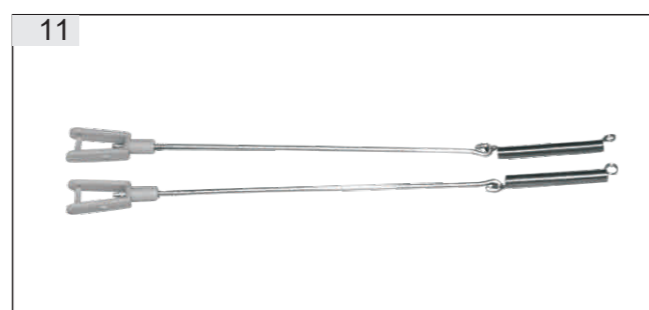
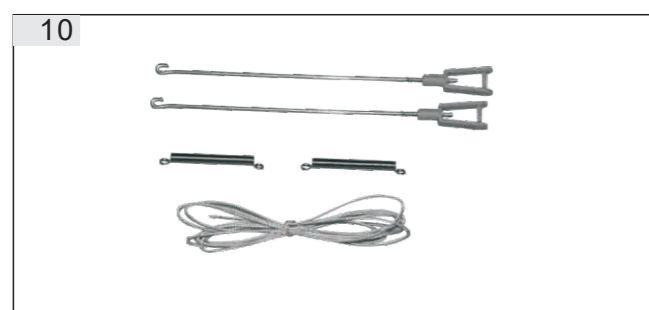

(6) The installation of battery bandage (17~19).

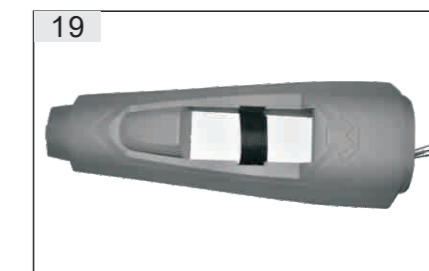
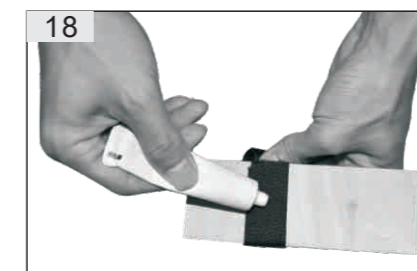

(7) Canopy installation (20~25).



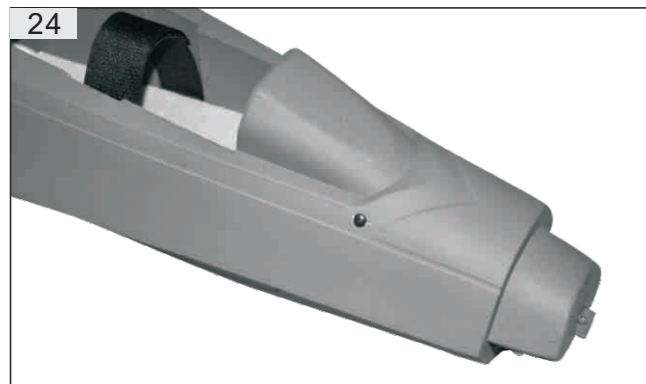
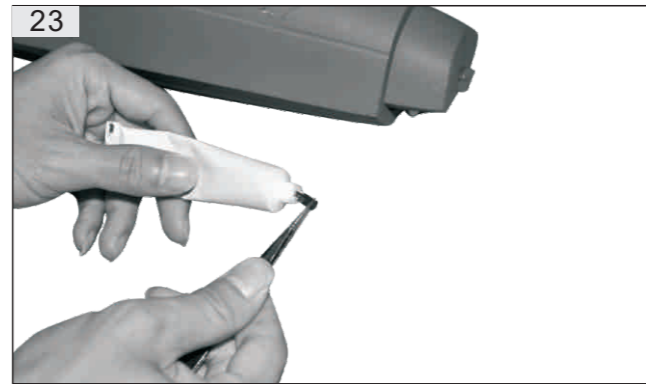
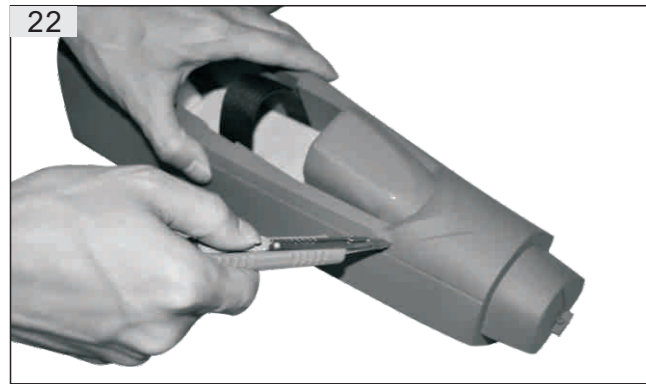

(8) Cowling installation (26~33).

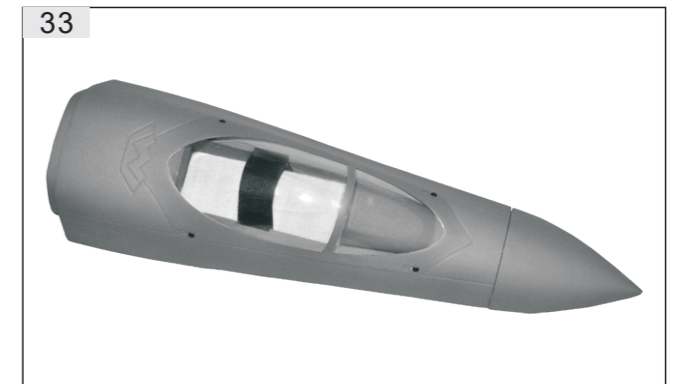
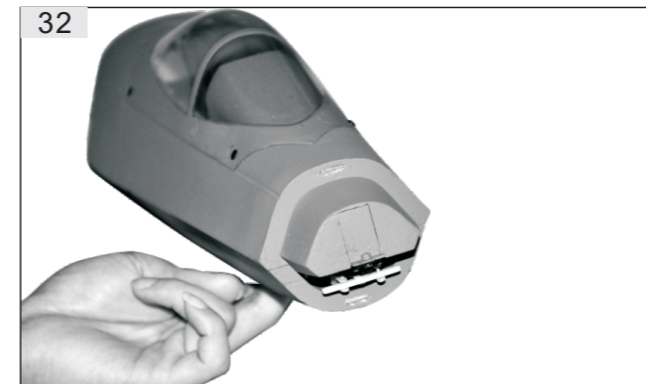
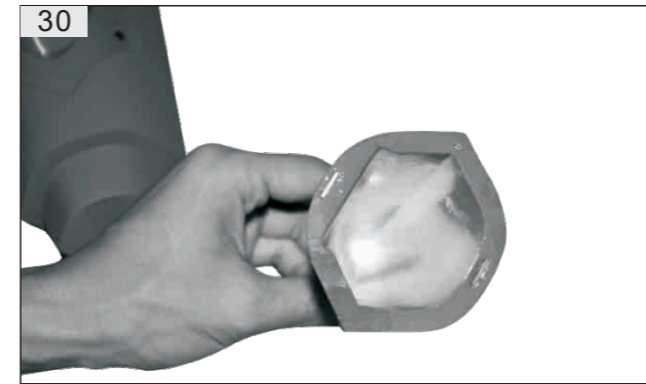
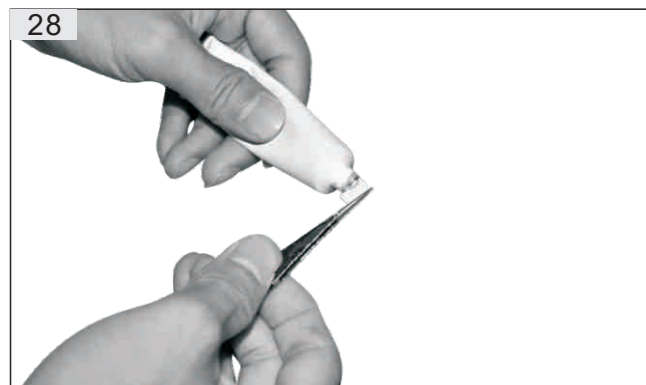

3 Back fuselage installation.

(1) The installation of Horizontal tail, aileron, flap, retract and brake wheel extend line. (34~35)

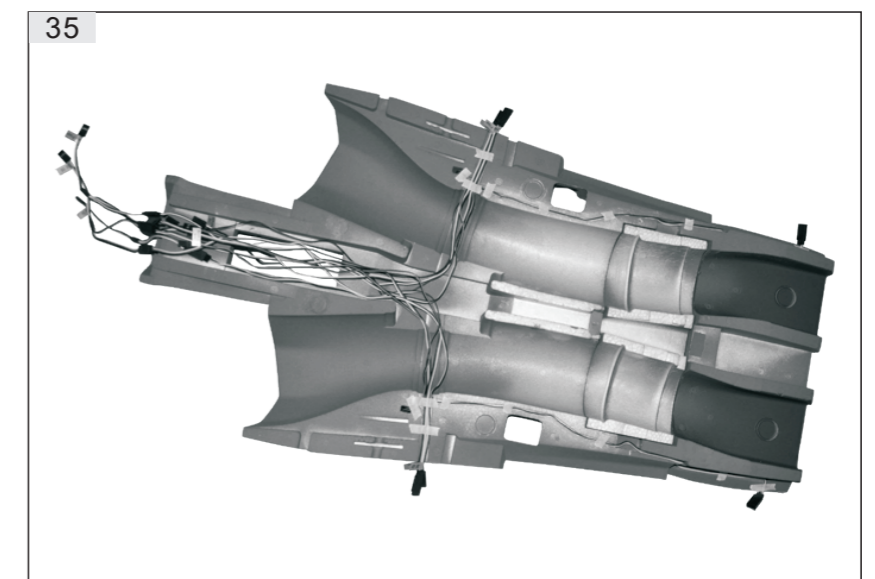
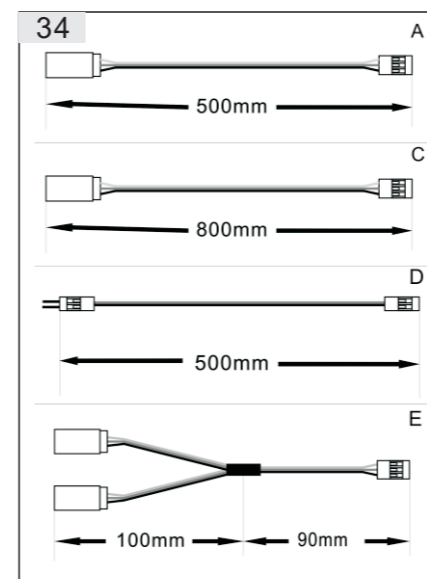

(2) The installation of the wire casing cover and cooling fin. (36~41).

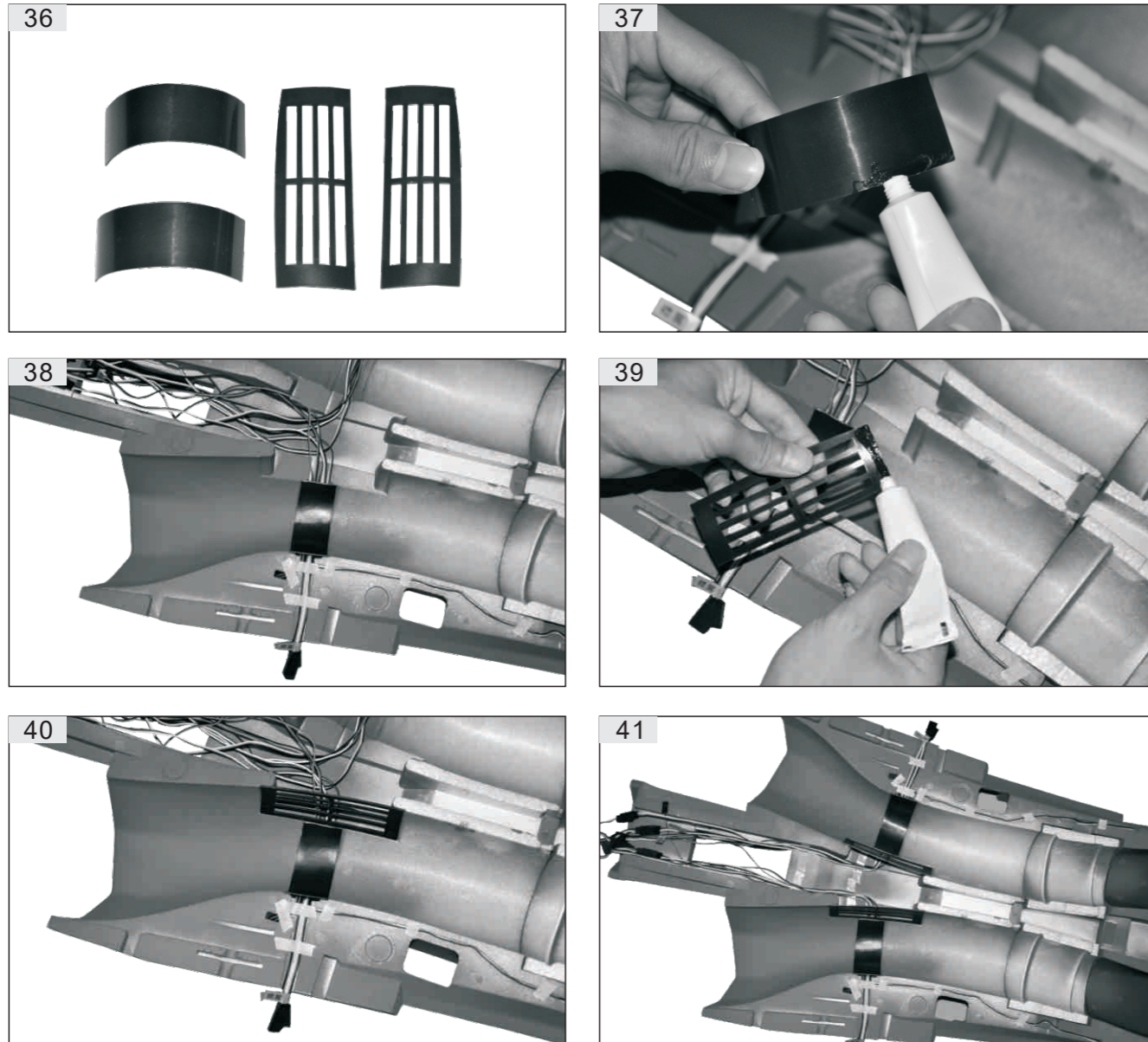

(3) The installation of EDF and ESC (42~44).

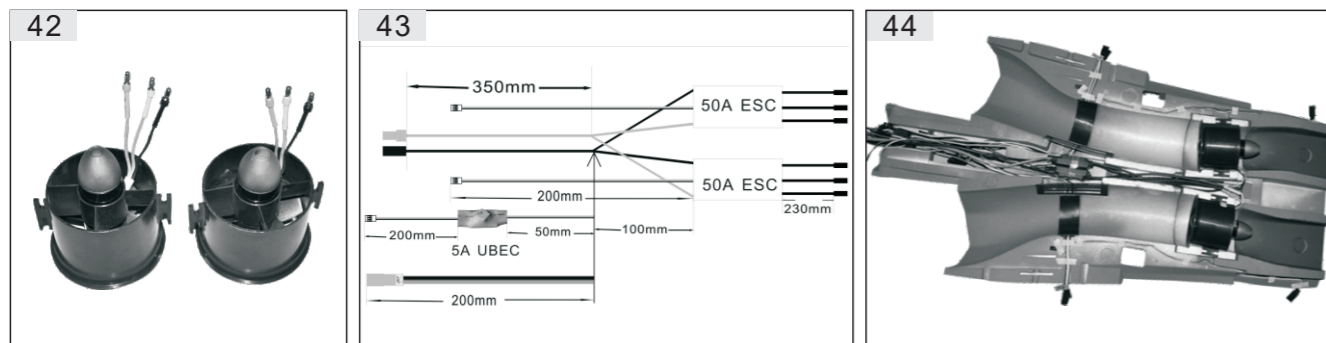

(4) The wing plug installation (45~47).



(5) The bonding of back fuselage (48~49).

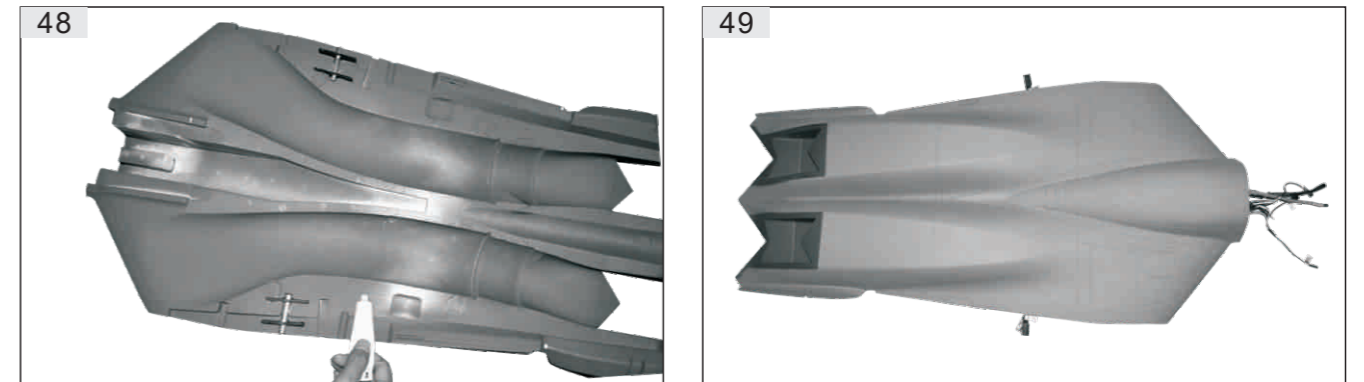

(6) The installation of the permanent seat of EDF cover (50~51).

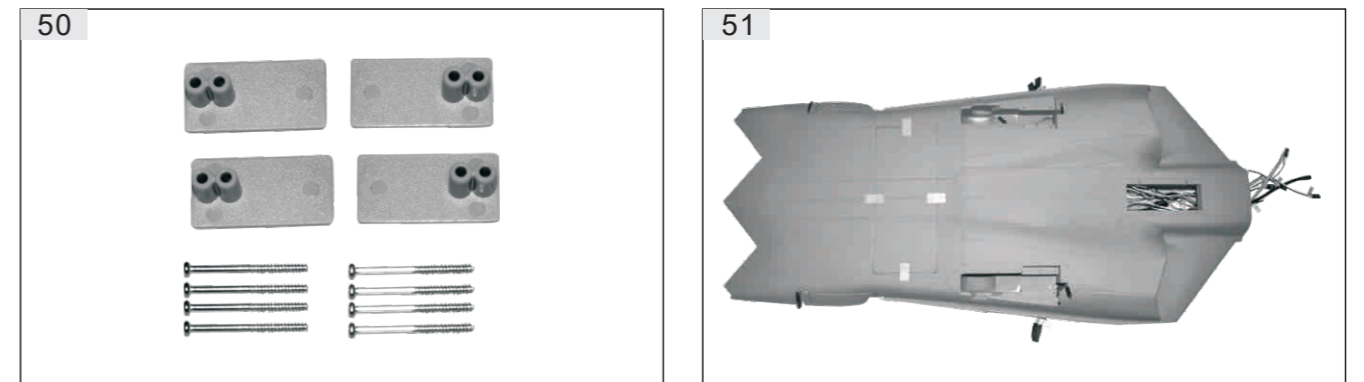

(7) The installation of receiver case (52~53).

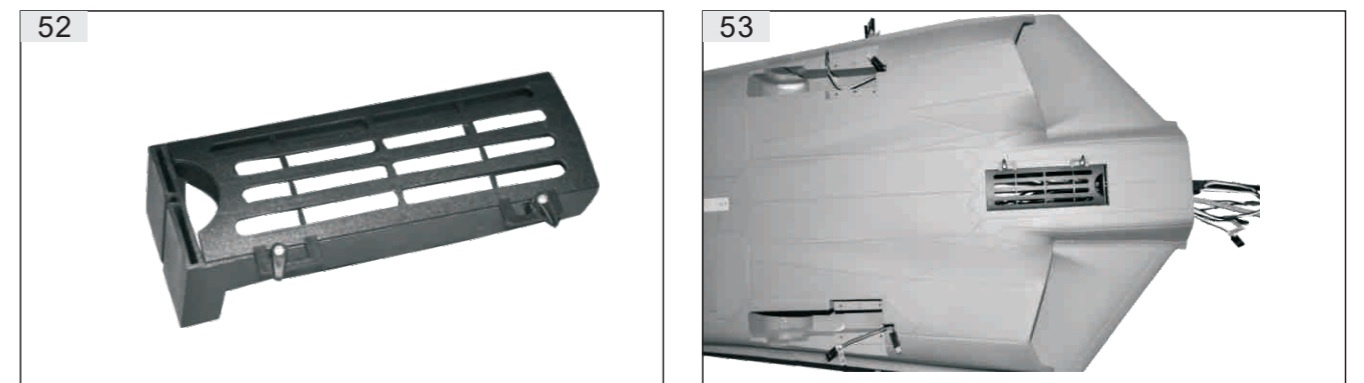

(8) The installation of rear retract (54~56).

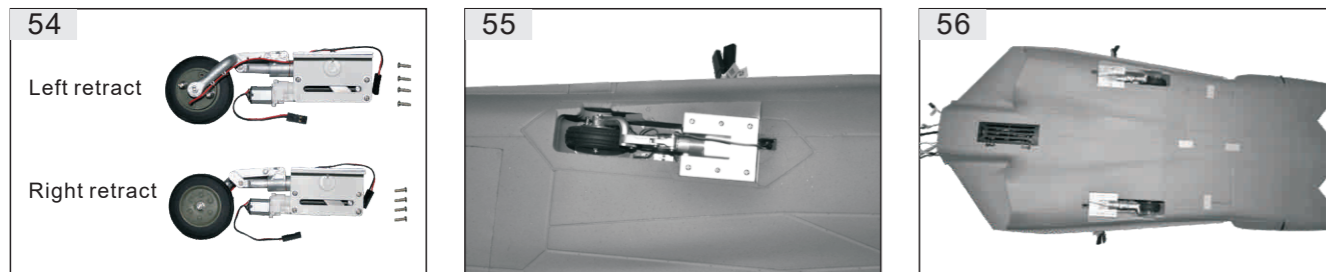

4 The wing installation.

(1) Aileron installation (57~60).

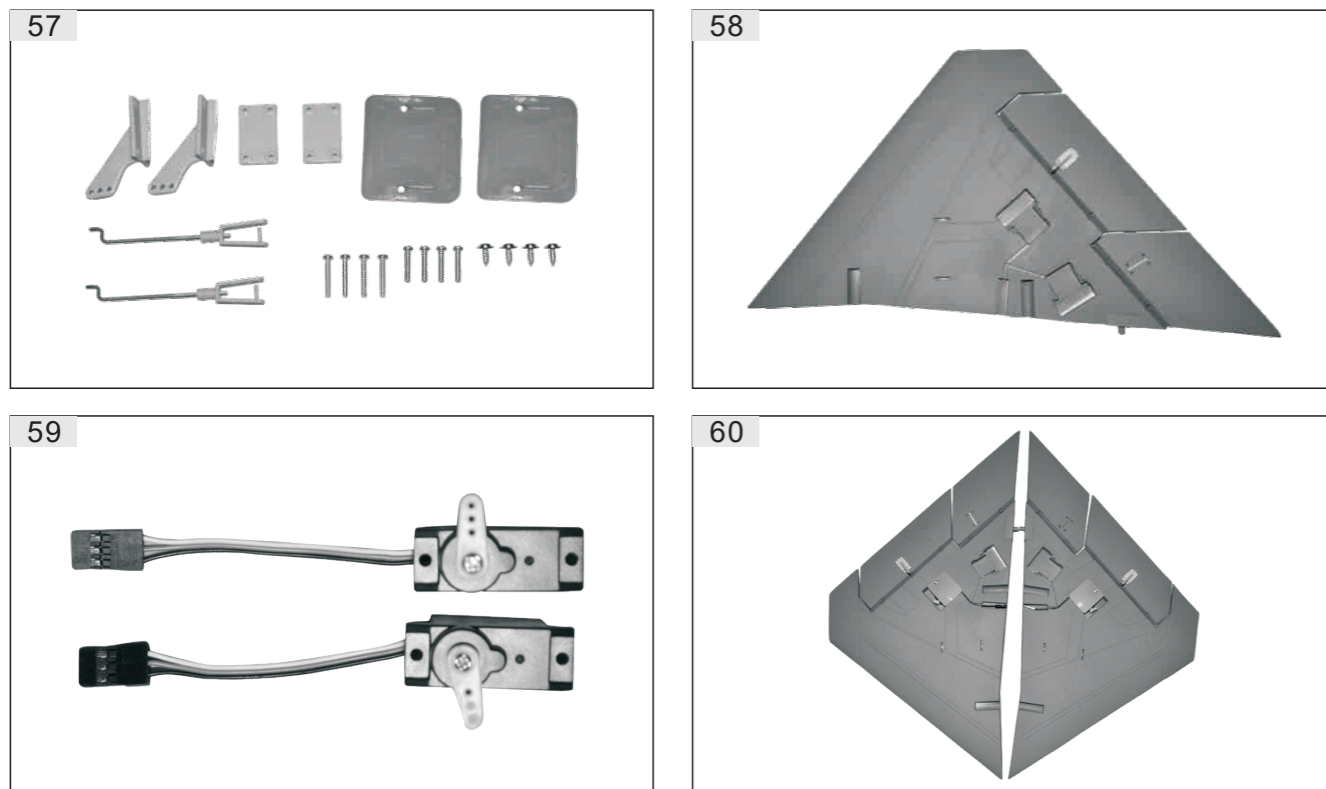

(2) Flap installation (61~64).

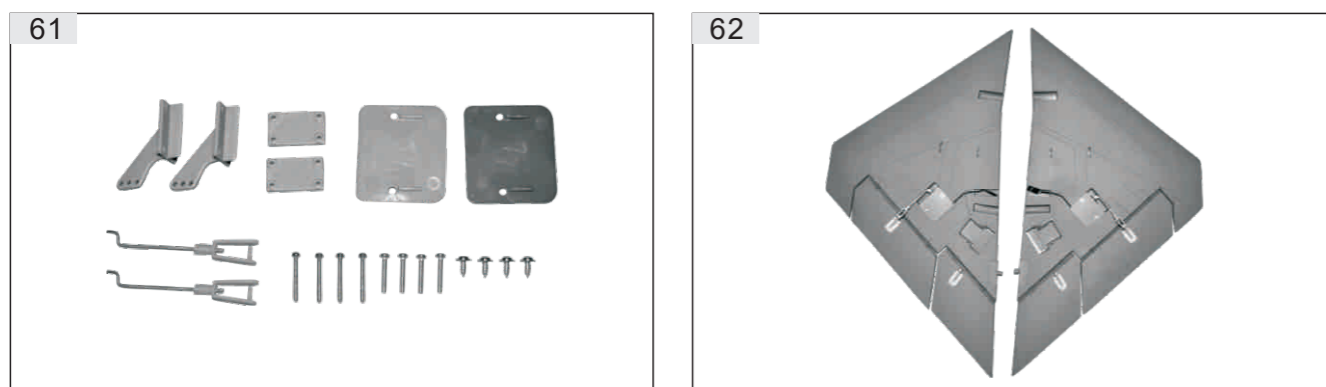

(3) Push rod installation(65).

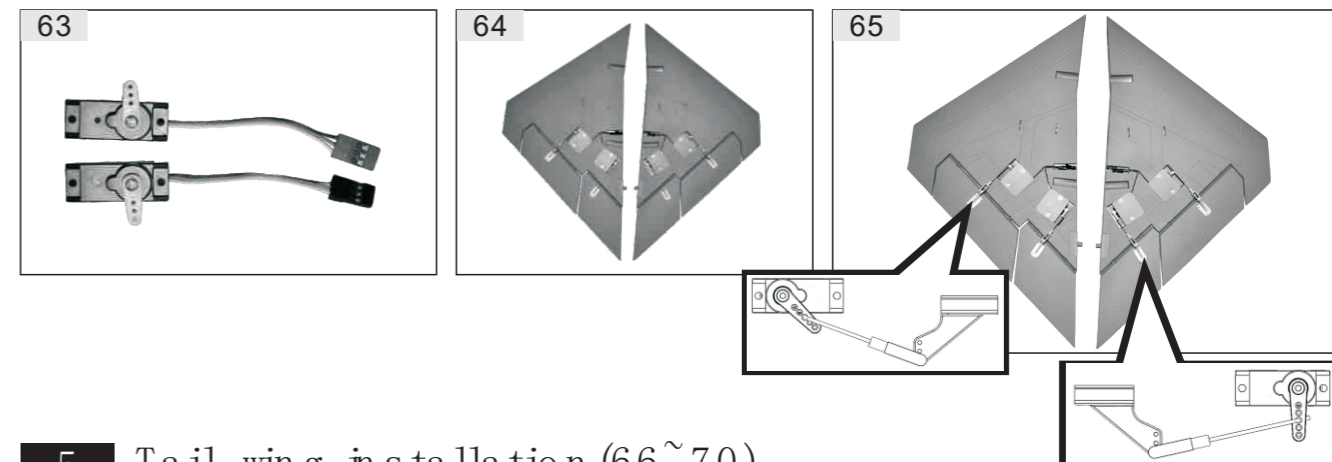

5 Tail wing installation (66~70).

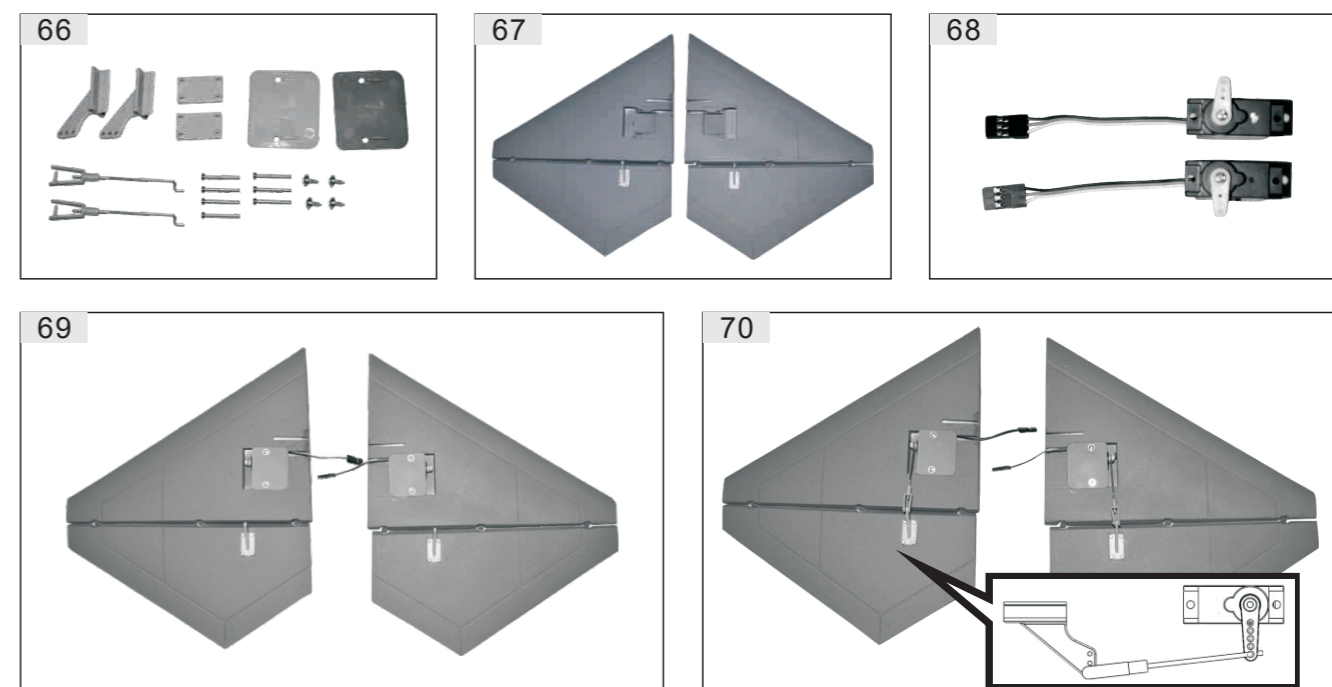

6 The connection of the front and back fuselage (71~72).

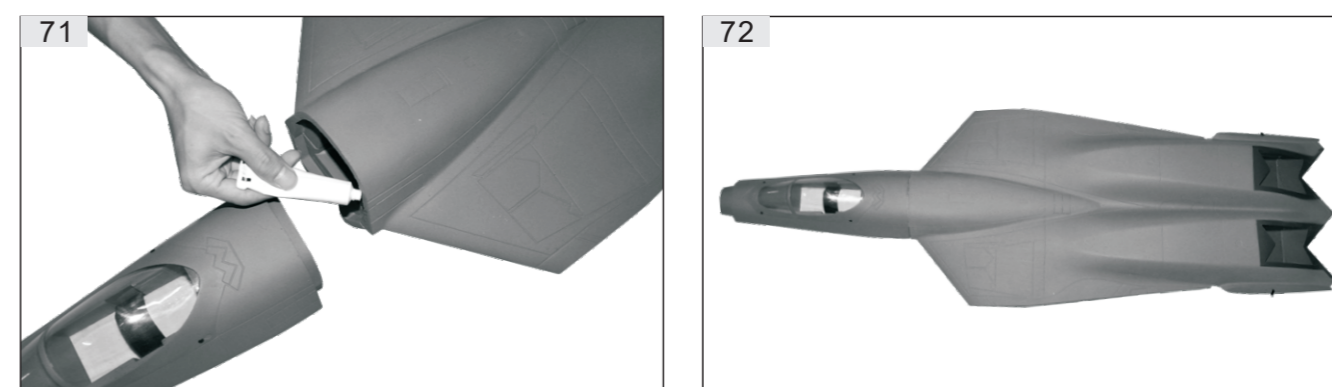

7 The connection of the wing and fuselage (73~79).

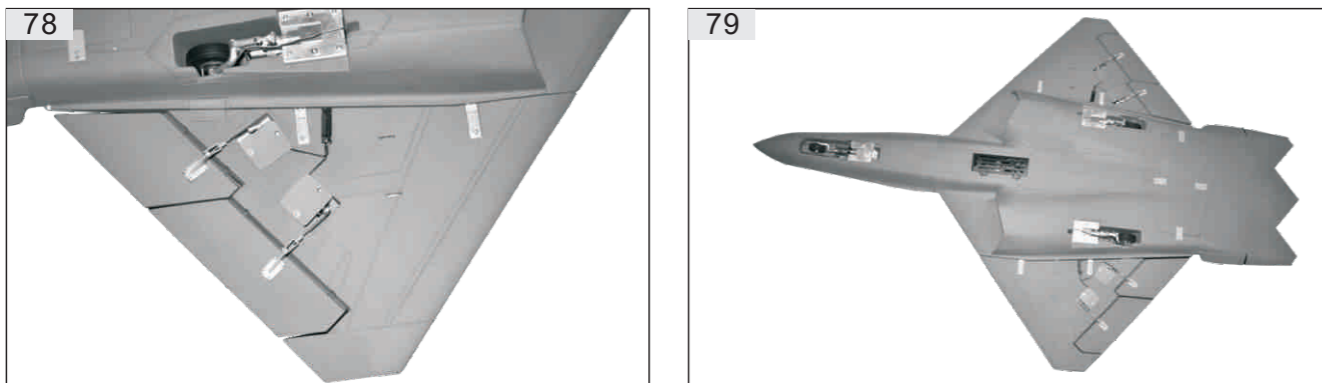
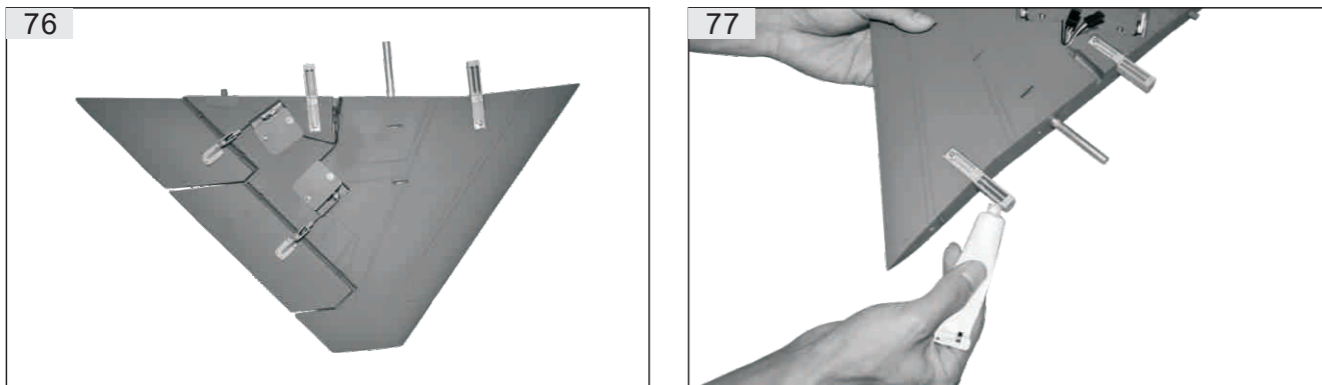
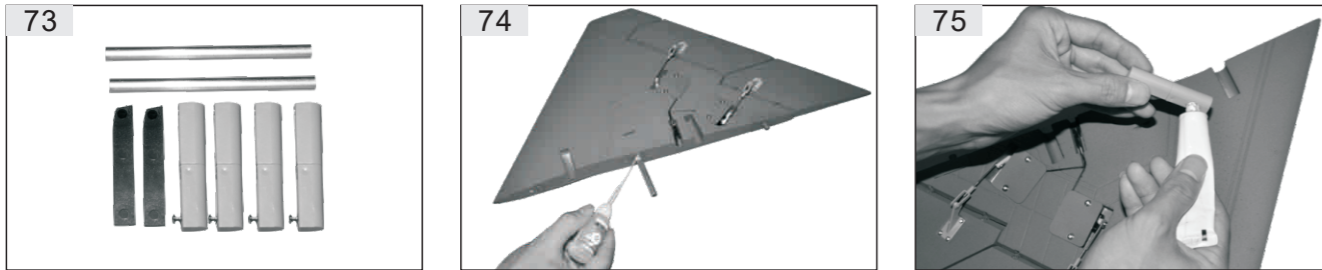

8 The connection of the tail wing and fuselage (80~83).

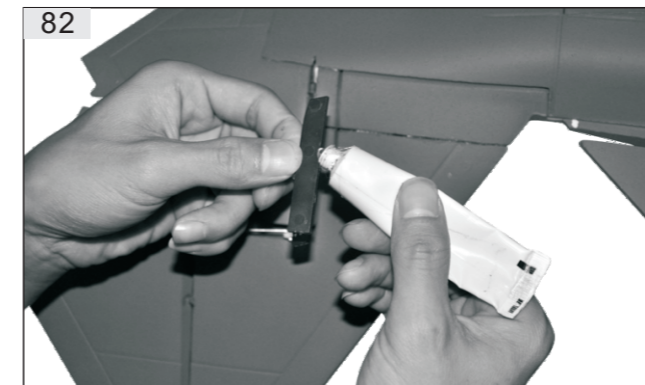
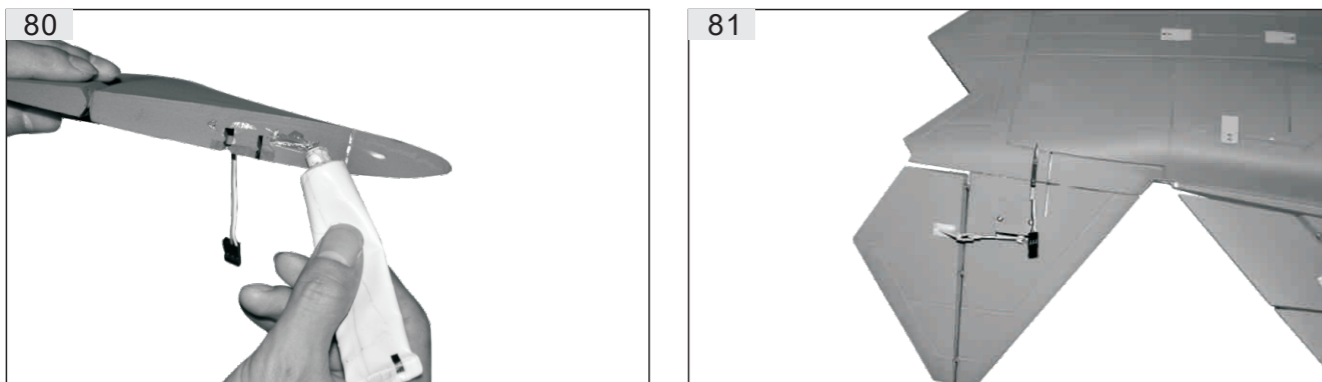

9 The receiver installation (84~99).

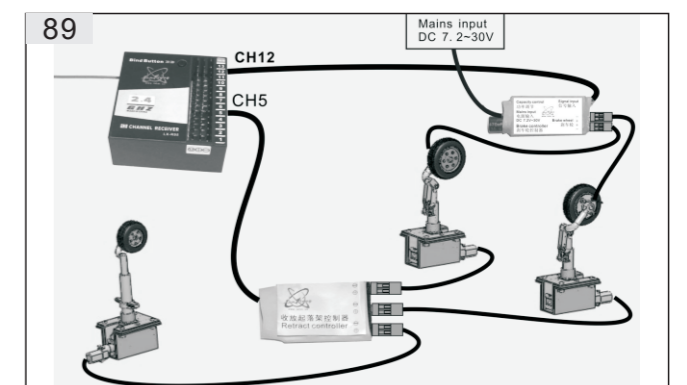
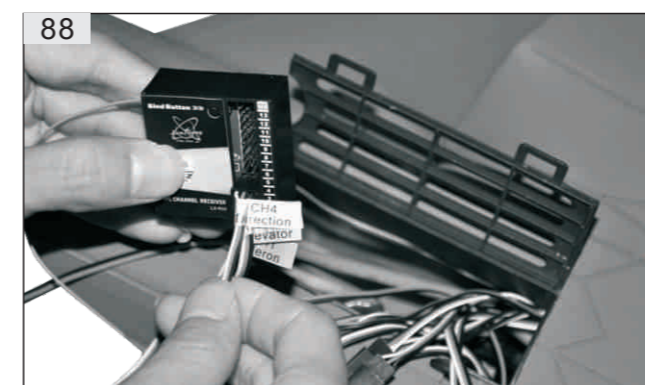
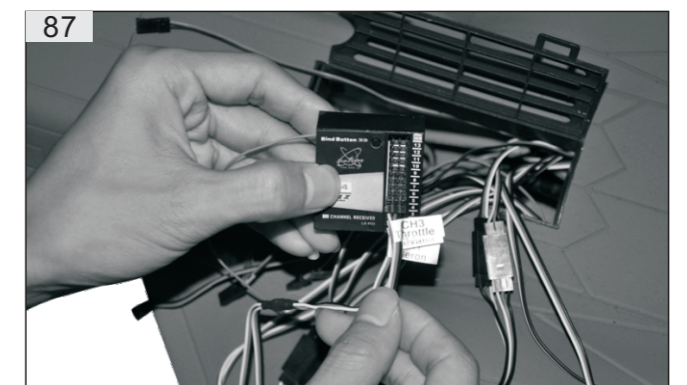
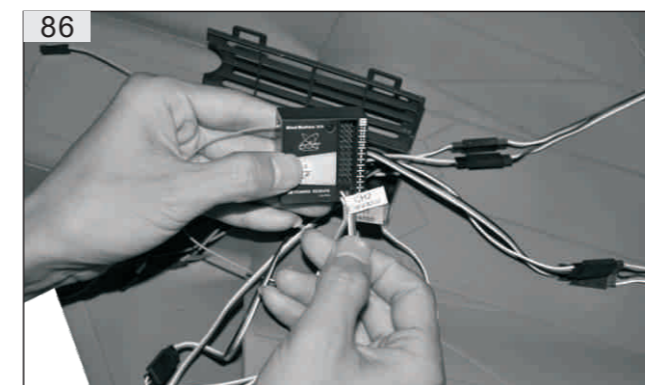
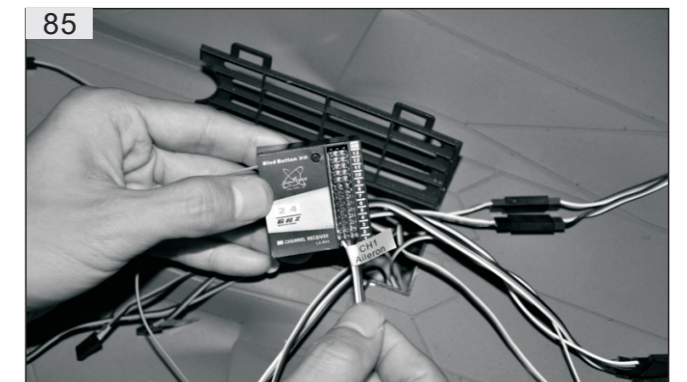

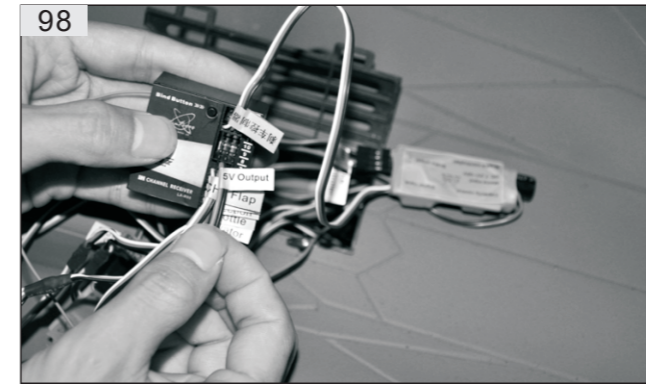
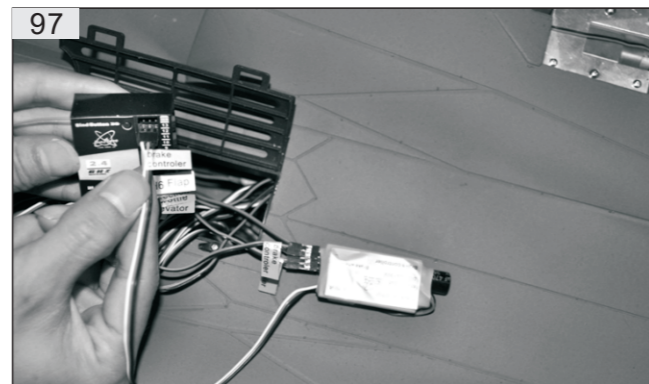
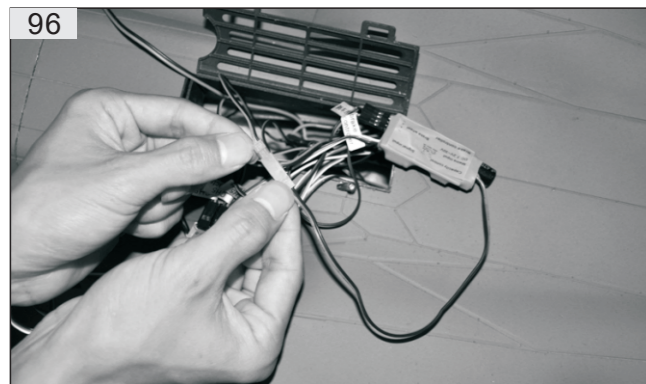
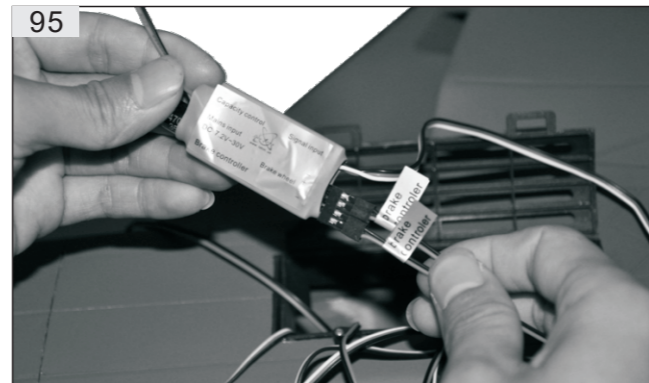
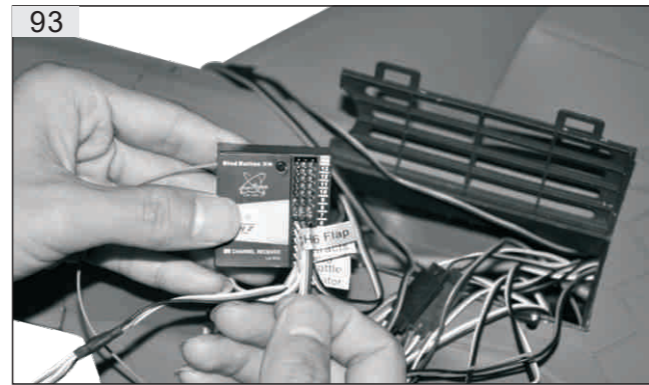
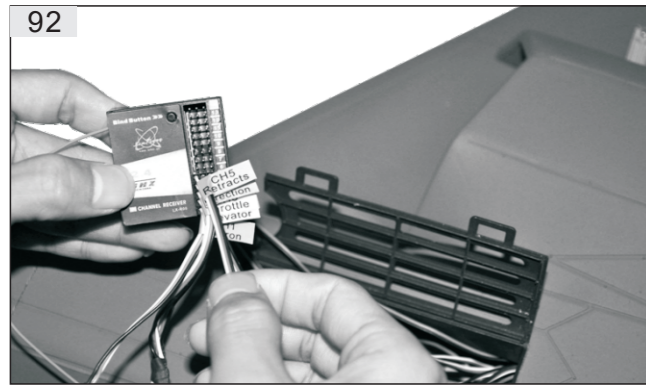
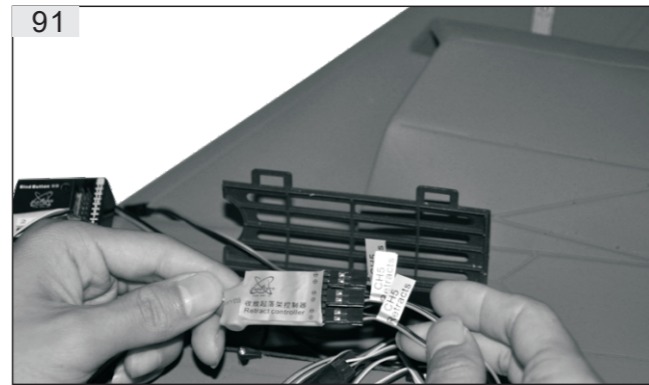

10 The power on of remote control (100~101).



11 Battery installation (102~105).

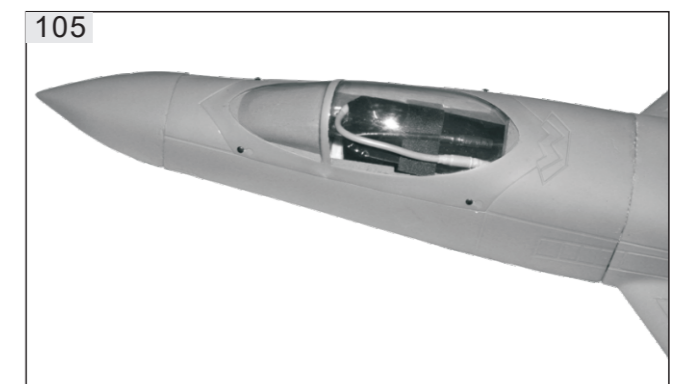

12 The setup of Throttle calibration (106).

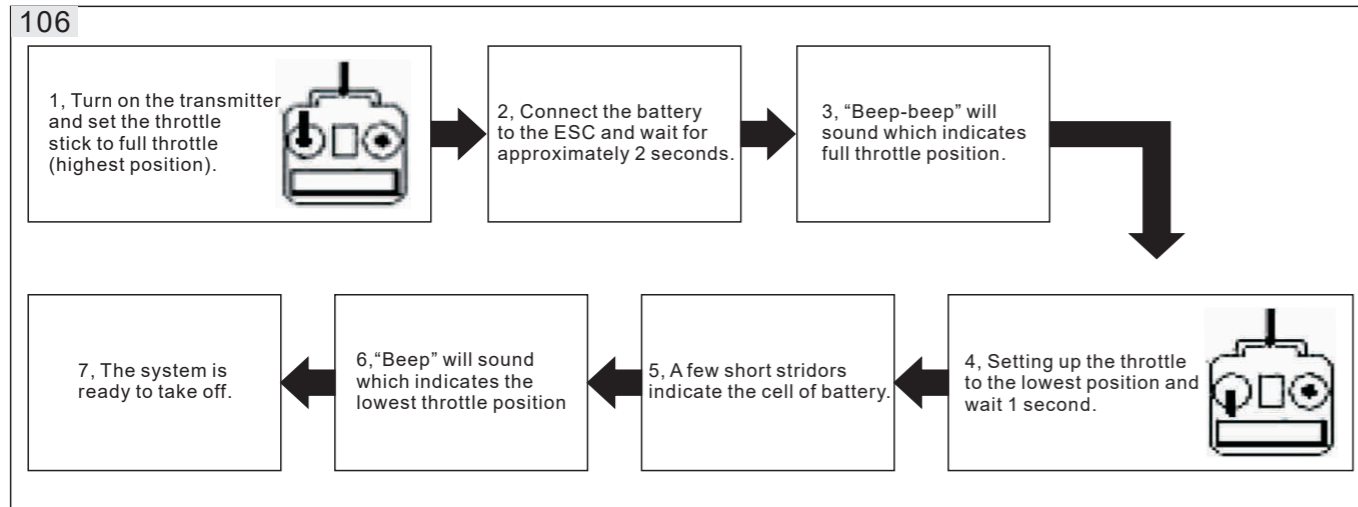

13 Channel Testing .

(1) Rudder testing(107~109).

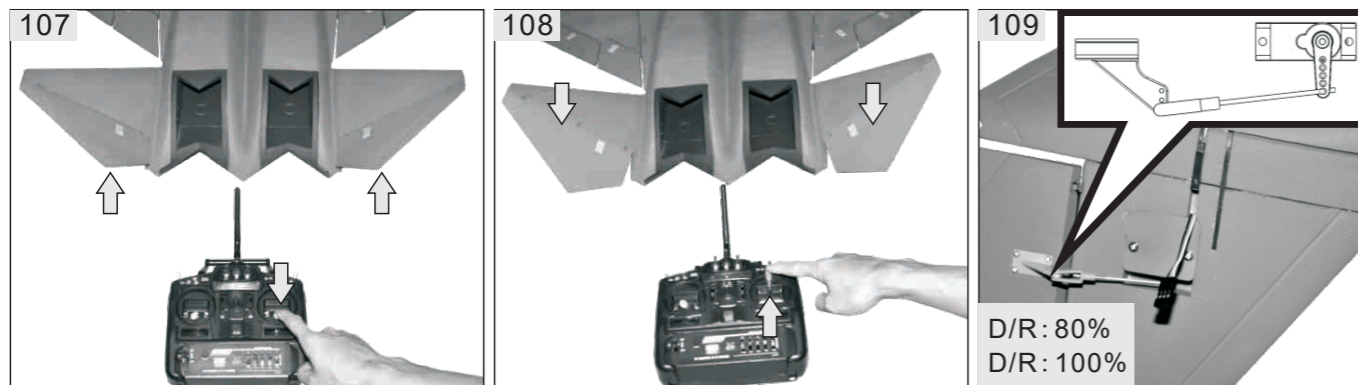

(2) Aileron testing (110~112).

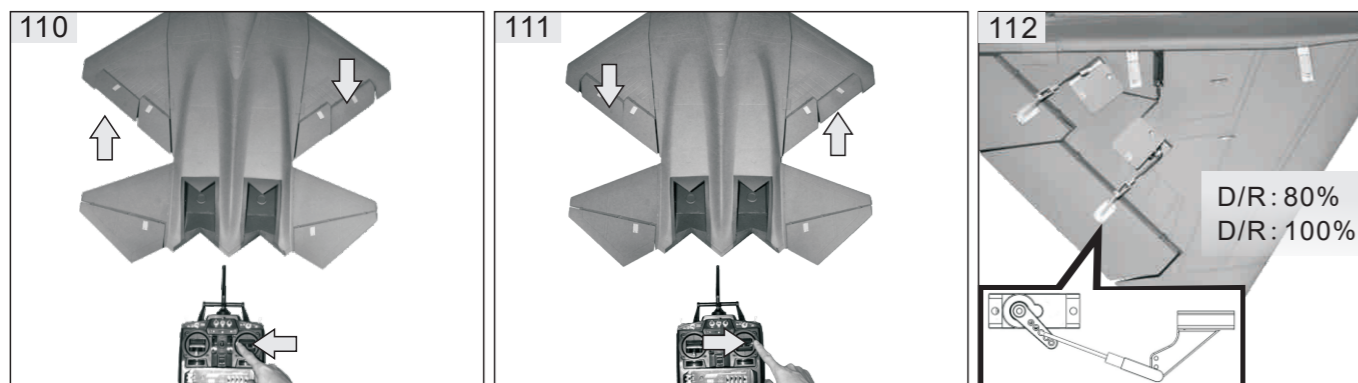

(3) Flap testing (113~114).

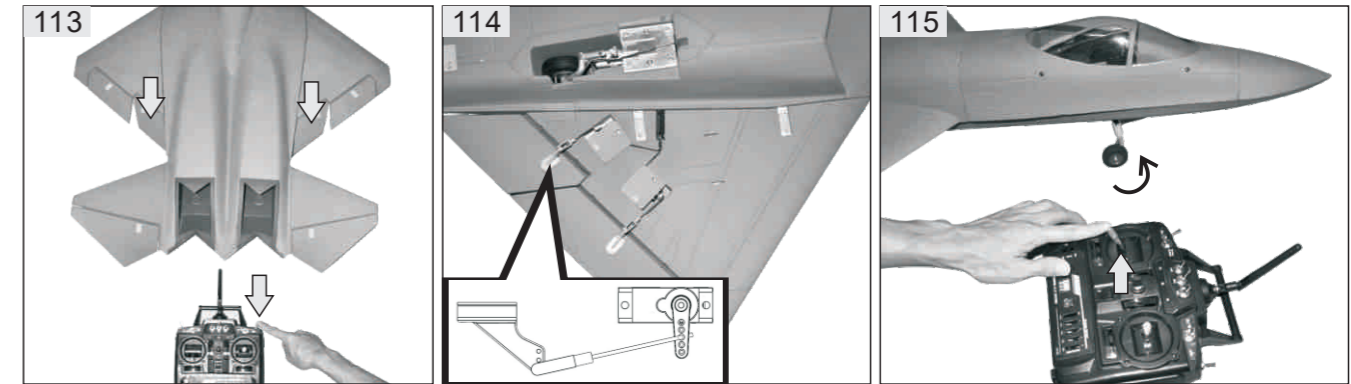

(4) Front-wheel steering (115~116).

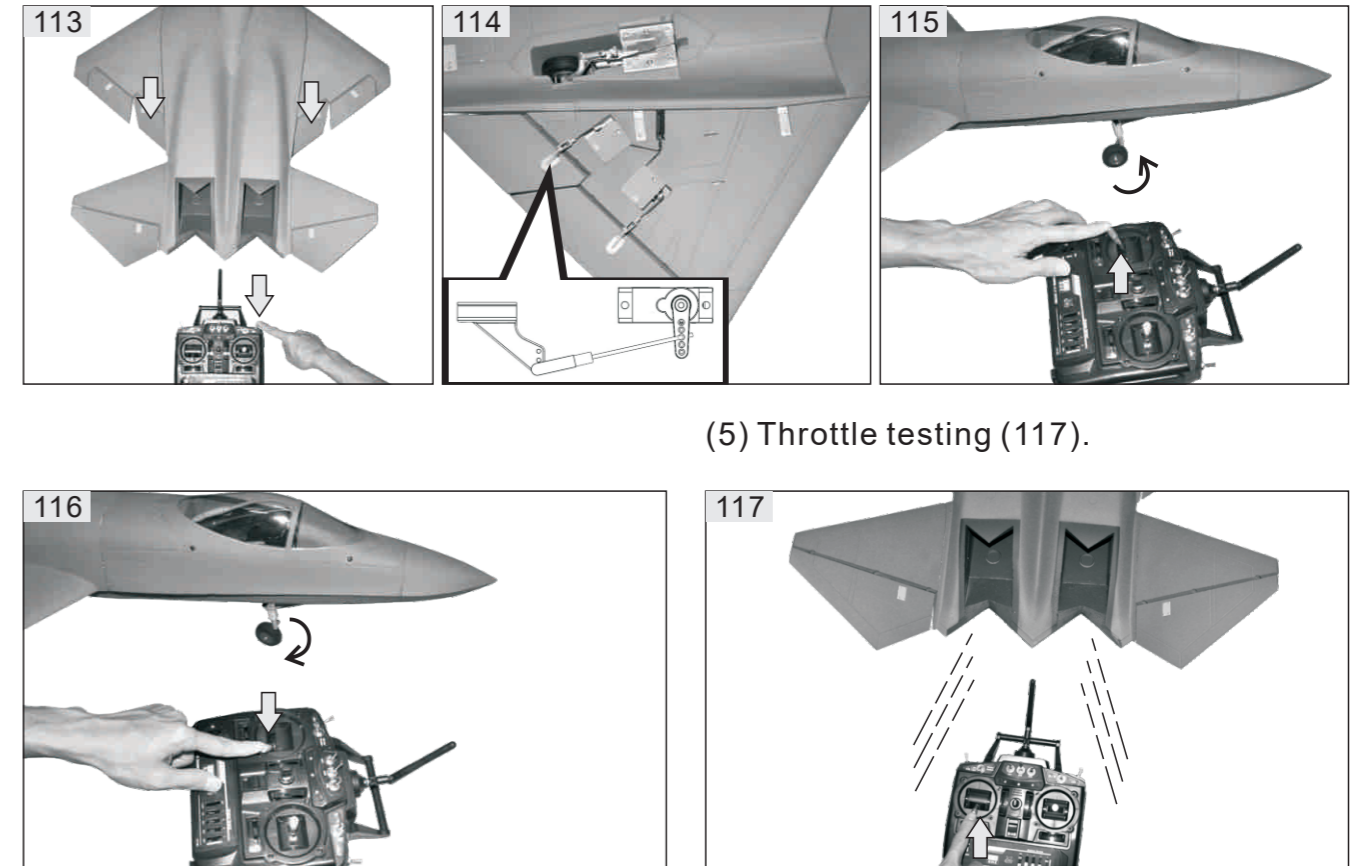

(5) Throttle testing (117).

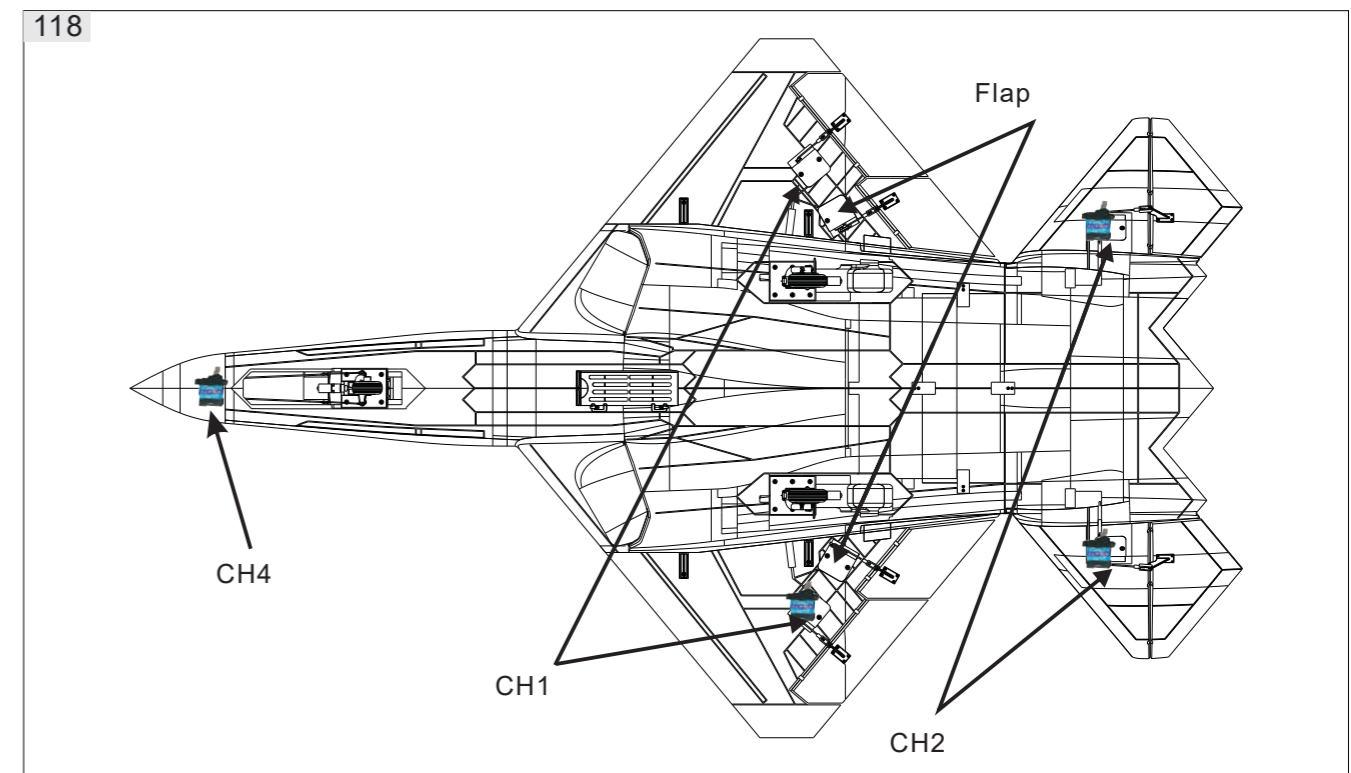
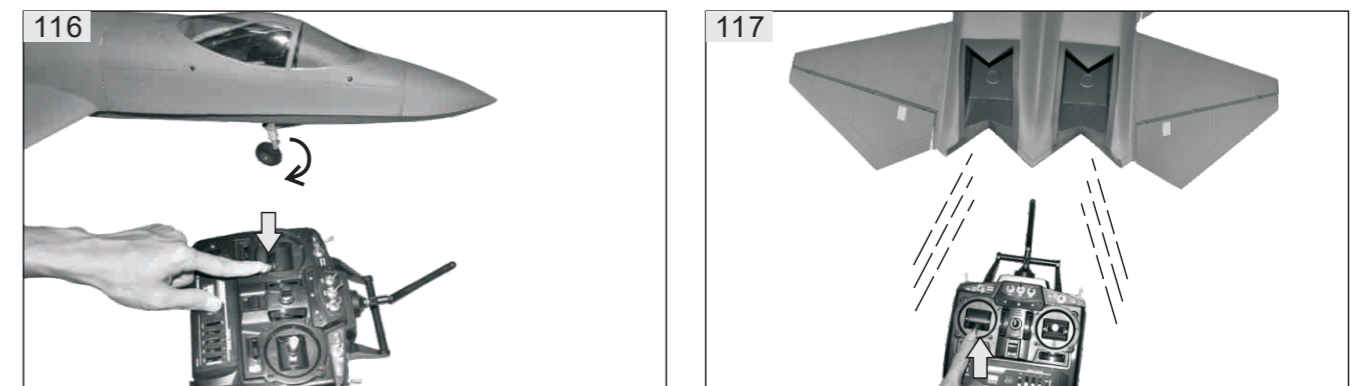

14 Beauty (119~132).

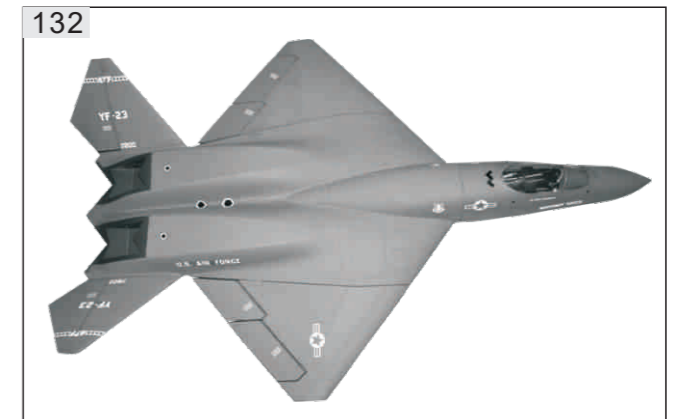
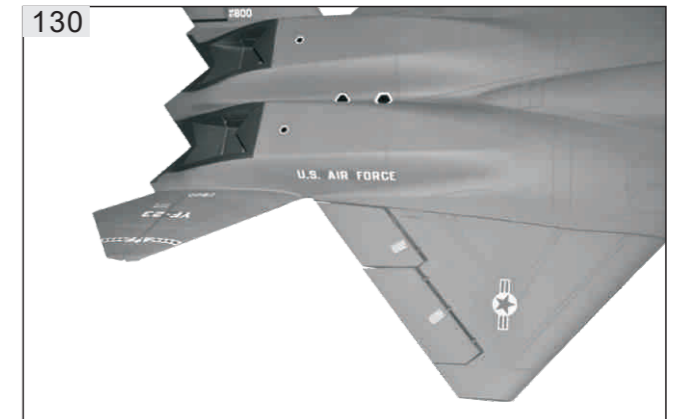
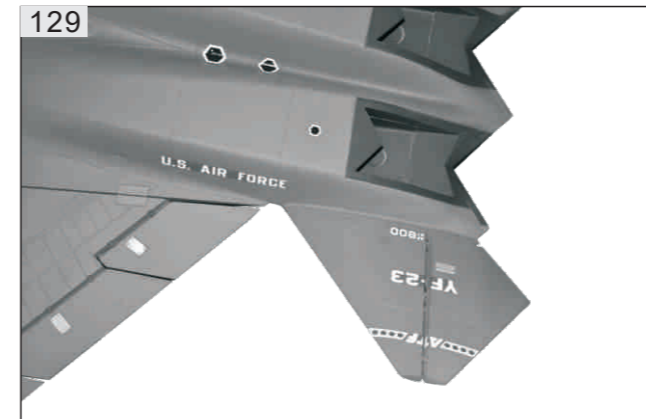
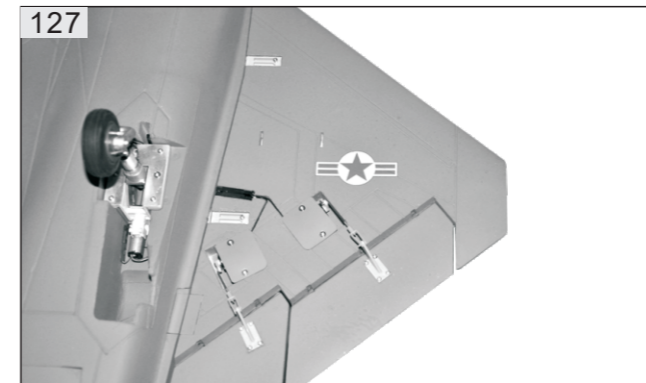
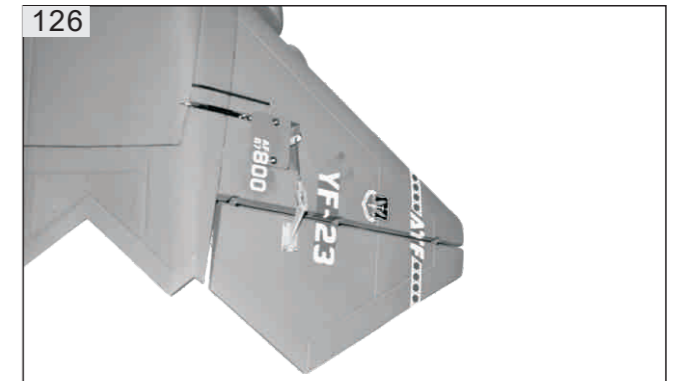
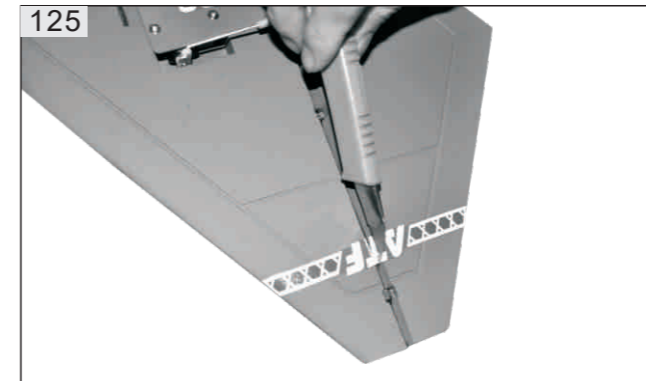
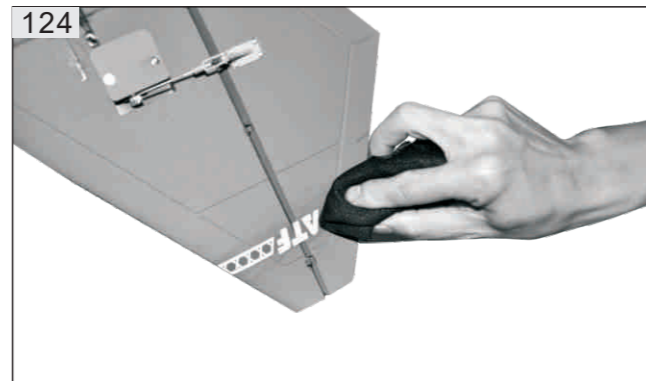
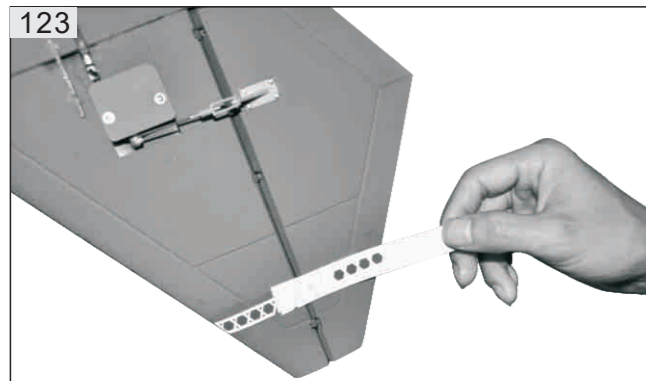
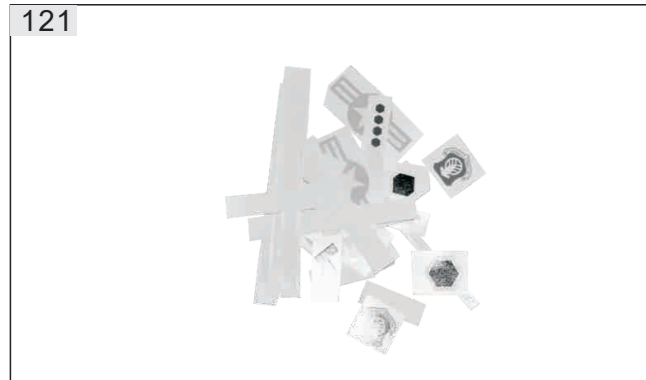
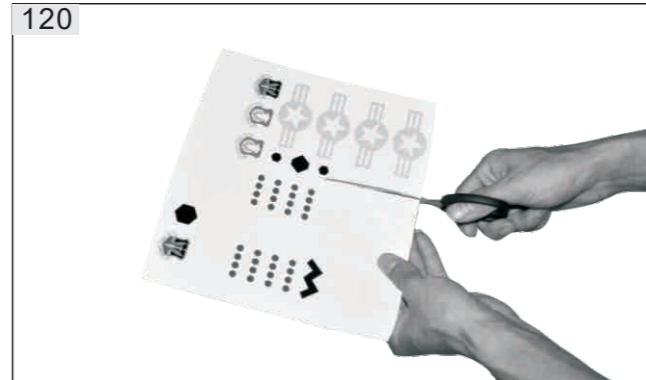
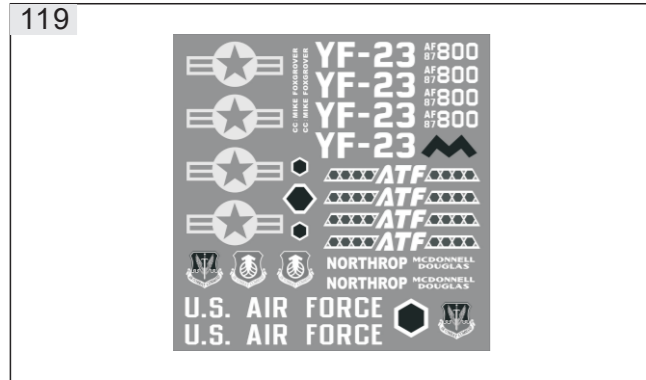

15 CG debugging.

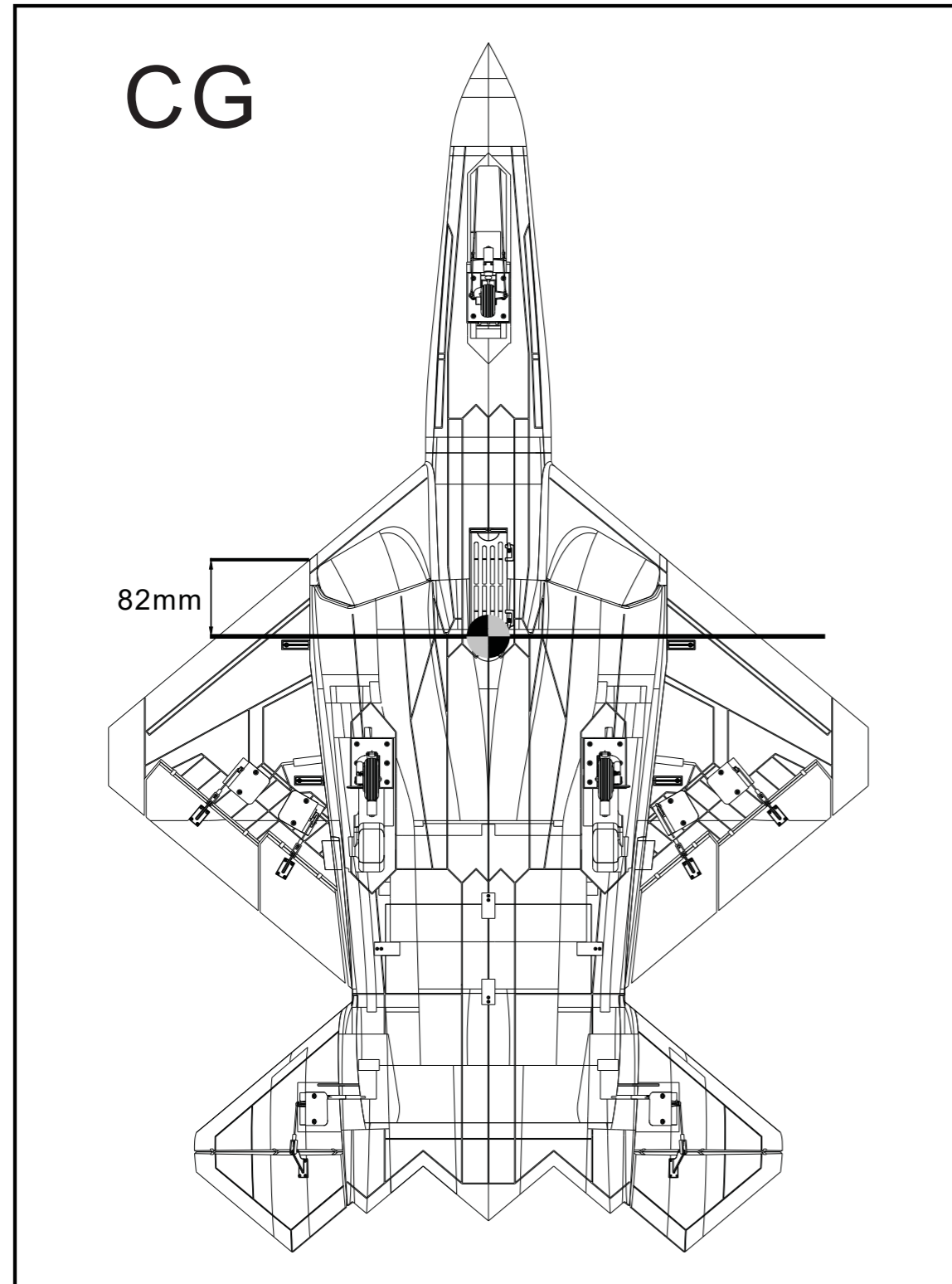

YF-23 Pre-Flight Check

1. Check carefully that every part of the plane is installed properly.
2. Always check that there are no other pilots using the same frequency in the same area.
3. Please switch on the power of the transmitter before connecting the battery. Make sure that the battery is fully charged.
4. Check that the plane responds properly to the control signals.
5. Extend the transmitter antenna all the way and test the range of the radio signal. With the transmitter and model switched on, step back around 20m and test the interference. If there is no interference, the plane is ready to fly. more information, please visit www.skyflighthobby.com

Problem Solving

Phenomenon	Typical error	Problem solving
Motor do not work	The battery is not full charged The battery of the transmitter is in low power. There is some broken circuit in the plane	Charge the battery Replace the battery in the transmitter. Contact your local dealer
Can not fly in a line	The rudder is not in the center of the fuselage The main wing is not installed in the center. The nose landing gear is rotary.	Adjust the trim on the transmitter. Reassemble the main wing. Verify the nose landing gear.
Can not climb	The battery is not fully charged. Elevator is still downward.	Charge the battery. Adjust the trim on the transmitter.
Short control distance	The battery of the transmitter is in low power. The antenna is not fully extended.	Replace the battery of transmitter. Extend the antenna fully.

16 Parts List .

NO of Accessories Bag	Name of Accessories Bag	Quantity	RTF	ARF	KIT
YF23-001	Extension cord	1	✓	✓	✗
YF23-002	The screws of fixing steering servo	1	✓	✓	✓
YF23-003	Front wheel steering	1	✓	✓	✓
YF23-004	Fixing battery	1	✓	✓	✓
YF23-005	The permanent seat of canopy	1	✓	✓	✓
YF23-006	Magnet	1	✓	✓	✓
YF23-007	Wire casing cover and cooling fin	1	✓	✓	✓
YF23-008	The wing plug permanent seat	1	✓	✓	✓
YF23-009	The EDF permanent seat	1	✓	✓	✓
YF23-010	Receiver case	1	✓	✓	✓
YF23-011	For aileron	1	✓	✓	✓
YF23-012	For flap	1	✓	✓	✓
YF23-013	For tail wing	1	✓	✓	✓
YF23-014	For connector	1	✓	✓	✓
YF23-015	Spare chucks	1	✓	✓	✓
YF23-016	Glue	1	✓	✓	✓
YF23-017	Decal	1	✓	✓	✓
YF23-018	For front retract	1	✓	✓	✓
YF23-019	For rear retract	2	✓	✓	✓
YF23-020	Retract controller	1	✓	✓	✓
YF23-021	Brake controller	1	✓	✓	✓
YF23-022	70mm EDF	2	✓	✓	✓
YF23-023	Motor	2	✓	✓	✗
YF23-024	50A ESC	1	✓	✓	✗
YF23-025	Servo	1	✓	✓	✗
YF23-026	Battery	1	✓	✗	✗
YF23-027	12ch Transmitter	1	✓	✗	✗
YF23-028	12 ch Receiver	1	✓	✗	✗

